

THE TRAMP

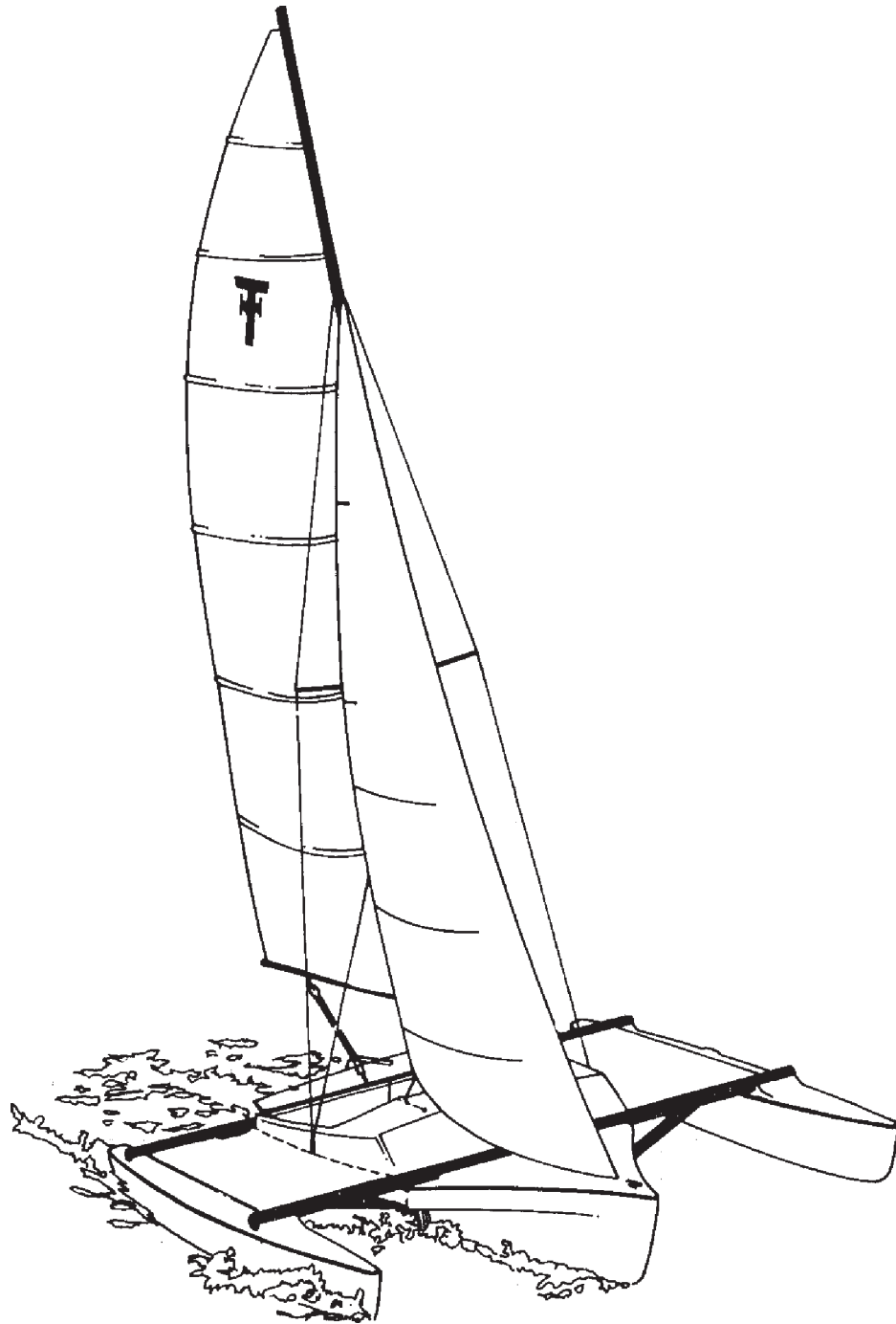

Sailing Manual

Reformatted and reprinted December, 1997

The TRAMP/EAGLE SAILING MANUAL

(the Eagle is the U.S. built version of the Australian built Tramp)

Congratulations on owning one of the most practical small sailboats afloat. Having seven water-tight sections, and submersible floats that allow a 14' 9" unfolded beam, the Tramp is one of the safest and most stable boats on the water.

Although not intended to be an ocean going vessel, the Tramp's ability to point high together with its 14" draft (board up) allows it to be sailed practically everywhere, from coastal sailing to lakes, rivers, and bays.

The purpose of this sailing manual is to familiarize you with the features of the Tramp, and to suggest recommended operating techniques. As you become more familiar with the boat, you may discover alternative methods of operation that are more comfortable.

CAPACITY

As with any boat, loading is important in terms of number of people on board and amount of carry-on items. As a rule, heavy items should be stored in the aft section, with only light items in the bow.

For good weather and day-sailing, up to six persons can be carried. For extended cruising or bad

weather, carry no more than four. In general, to maintain good performance and easy handling, it is preferable to limit the crew to 4 adults, with 1 or 2 children. You can tell if the boat is overloaded, as water will enter through the cockpit drains when heeled slightly.

TRAILERING

The total towing weight (including trailer is approximately 2,275 lbs. not counting personal gear, safety items, etc.). For easy, no sway towing, the trailer should be balanced to give between a 100 to 200 lb load on the towball.

The four beam locking pins (retain the floats in the folded position) should be in place and the floats tied down to the trailer at the tie down points. The center hull side supports should be hard against the hull. The float supports should also be hard against the floats. The supports for the floats are not intended for bearing their weight but to provide lateral stability on the highway and enhance the overall ride. The weight of the floats is carried by the folding arm mechanism and the main hull.

While trailering, allow extra distance for stopping. The overall height of the boat on the trailer is

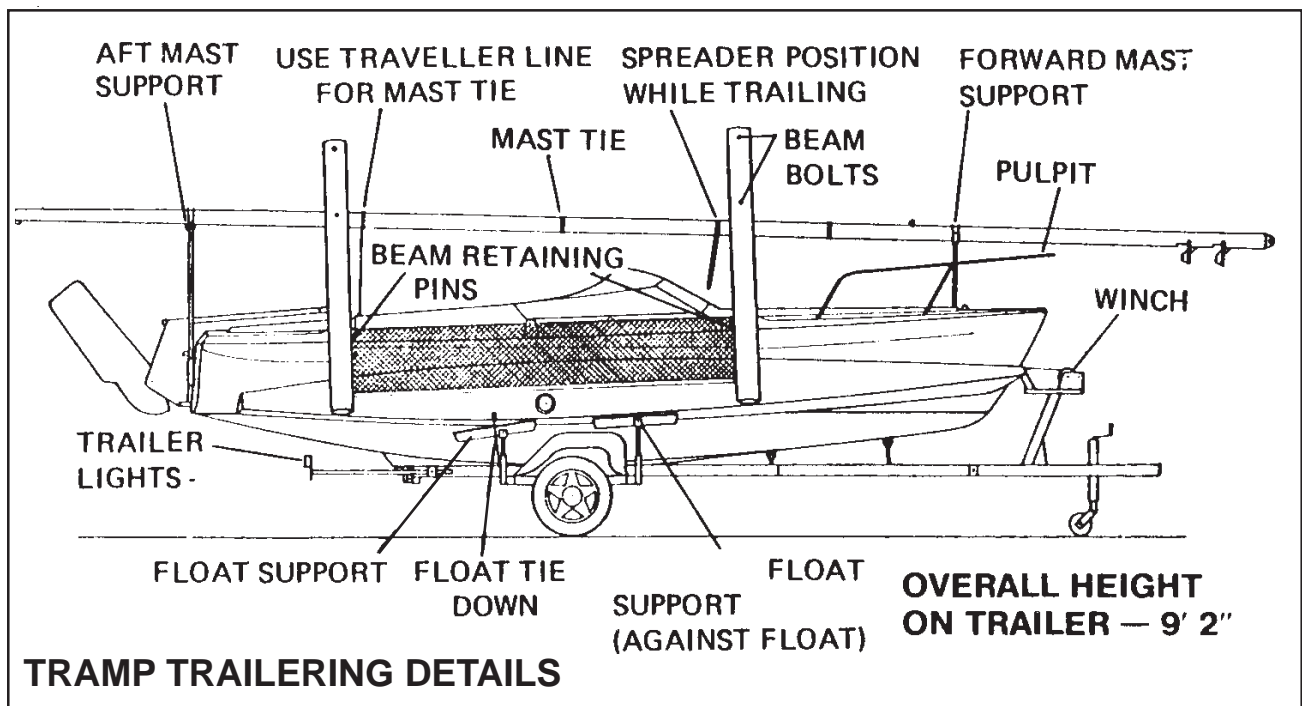

about 9' 2" As a result, care should be taken to watch for low clearance bridges, overhanging tree limbs, etc. Should it be necessary to take the boat under a low obstacle, the height can be reduced by unfolding the floats. Although the extended floats will increase the beam width, the height can be significantly reduced.

OUTBOARD MOTOR

An outboard motor well is located aft of the cockpit on the port side. It will accommodate a 4 to 6 HP, long shaft, outboard motor. The motor can be used while the floats are extended or folded. In most situations, an internal gas tank housed within the motor housing is sufficient for most motoring needs. The usual tank capacity is approximately 2 quarts and will provide about 2 hours of operation at two-thirds power. If a separate gas tank is required, it should be placed in the aft storage compartment, with the fuel hose fitted through the outboard well side. The motor should

always be tilted when launching or sailing and two fittings are provided near the well as hold-down points for an elastic strap if needed to maintain the motor in the tilt position.

The 4 to 6 HP motor will provide 6 to 7 knots of speed for the Tramp.

RIGGING

Before rigging, check to ensure there are no powerlines that the mast could touch while being raised or while the boat is being backed to the launch ramp.

For added stability, rig the Tramp on level ground so balance is maintained while raising the mast. Remove the float tie down lines and leave the float supports against the float. Climb onto the deck using the float bows as stepping points. Undo the mast/rigging ties and the mast support ties. The upper shrouds are now connected to the mast by

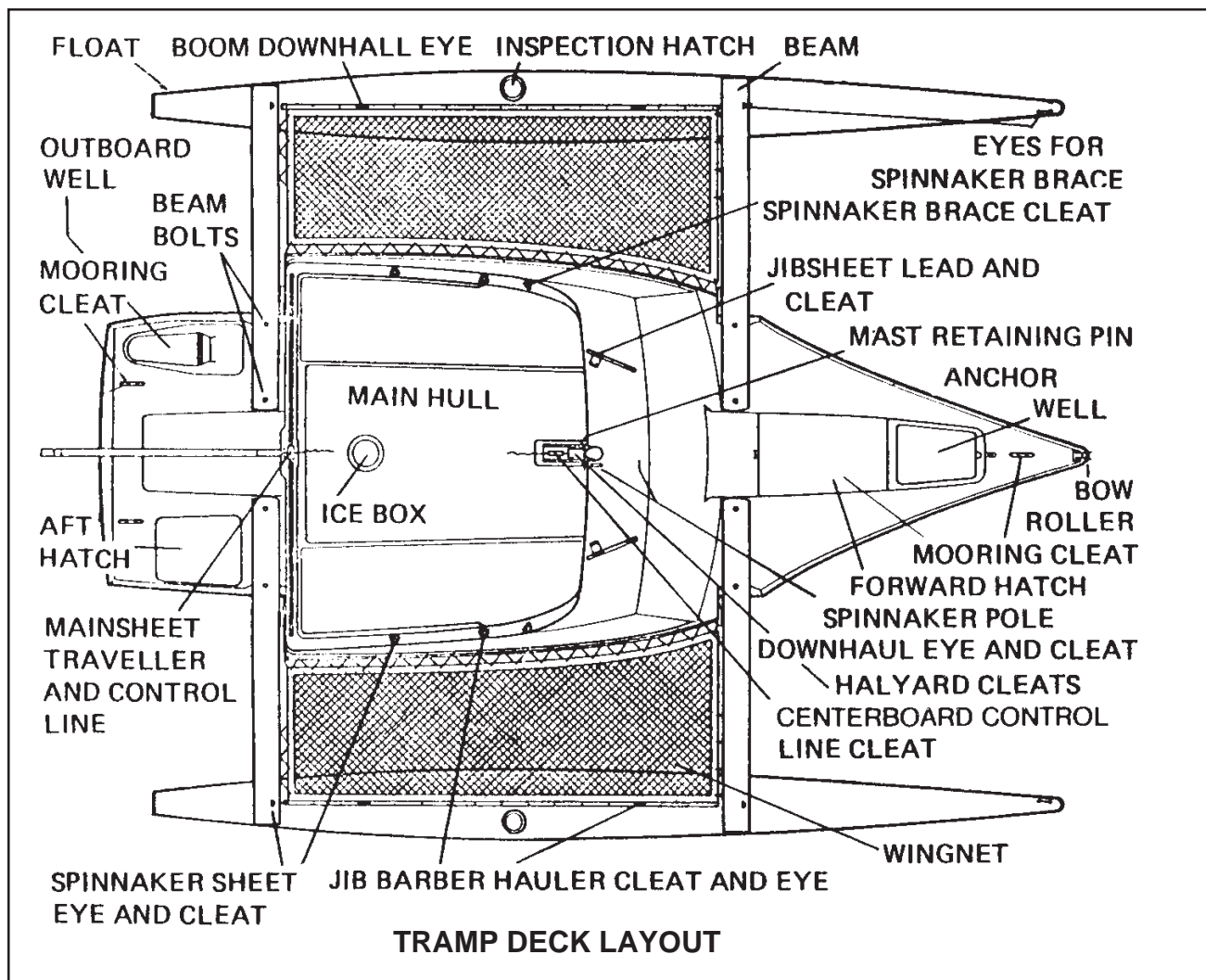

first guiding them through the spreader shroud slots, inserting them into the mast and giving a half-turn to lock them in place. The lower shrouds are now connected to the mast in similar fashion.

The stainless steel mast retaining pin is removed from the cabin roof. Lift the forward end of the mast from the forward mast support and walk aft rolling the mast along the aft mast support until the mast base will pass through the cabin roof slot. Lower the mast base through the slot and insert into the mast step.

Check that no obstructions will prohibit free movement of the shrouds when the mast is being raised. The average person will be able to raise the mast single-handedly. A second person can pull on the forestay, if desired. If the mast is too heavy, the trailer winch wire can be passed over the bow roller and hooked to the forestay. Lift the mast until it enters the cabin roof slot and replace the mast retaining pin, thus allowing the mast to stand on its own.

The shrouds are then connected very loosely, with the top shrouds connected aft of the lower shrouds on the side shroud plates. The forestay is connected and done up very tightly. The top shrouds are now tightened considerably, while the lower shrouds should be left slightly slack to allow the mast to bend forward in the middle. For more bend, and hence a flatter sail, loosen the lower shrouds. Once the shrouds are set, they are locked by lock nuts, and not loosened during future rigging or de-rigging evolutions. Only the forestay needs to be connected and disconnected.

As can be seen, one person can single-handedly rig the Tramp.

The boom is now pushed onto the gooseneck pin and the topping lift connected. With all battens tied in place, the mainsail can be made ready for hoisting by inserting the foot into the boom track. Now connect the mainsail halyard to the head and start the sail up the mast track. Secure the mainsail to the boom out of the way until you are in the water. The mainsheet is connected to the traveler. If the weather looks like it may deteriorate, the jiffy reefing lines should be fitted for the first reef.

If the spinnaker is to be used, the sheets and

braces should also be fitted now. As you unfold the floats in the water these lines will need to be slackened. Make sure that the centerboard pull-up line (red, port side) is cleated to avoid having the board catch on the trailer when launching. The rudder and outboard engine should also be tilted up. The boat is now ready to be launched.

LAUNCHING

Back the trailer down the ramp, again watching for powerlines, until the aft end of the boat is in the water. There is no need to submerge the entire trailer. Use a long bow line secured to the forward cleat. Simply pushing off will launch the boat. The tilt function of the trailer can be used, but it is usually not necessary. If able, it is good practice to walk down the trailer with the boat, to prevent any damage from the trailer. Float bows can easily come into contact with the trailer.

The usual practice of unfolding the Tramp floats is normally accomplished while motoring or sailing away (with jib) from the dock, even in choppy conditions. There is still a great deal of stability provided by the floats when they are in the folded configuration, but care should be taken.

To unfold, simply remove the locking pins at the forward and aft beams, grasp the handhold on top of the aft beam (it is not necessary to hold both) and firmly pull the beam down. Both forward and aft beams will lower together into the recesses provided, the float will unfold and the trampoline should extend and tighten. Make sure there are no lines lying in the beam recesses and that the tiller is clear. Kneel or stand on the beams and secure the beams with the bolts using the speed wrench provided.

RUDDER AND CENTERBOARD

Both the rudder and centerboard have 2 control lines, one to pull up and one to pull down. The pull up line for both is red. Both rudder and centerboard will kick back should they touch bottom, with the extension line pulling through the cam cleat.

When maneuvering in confined areas, always have the centerboard down, where possible. This promotes very quick turns and prevents sideways motion. If motoring, but at very low speeds, always turn the motor rather than the rudder. At low speeds the rudder is less effective, whereas the

TRAMP SAIL PLAN

SAIL	LUFF	LEACH	FOOT	WGT	AREA
MAINSAIL	23.89 ft	24.77 ft	8.14 ft	6oz	137 ft ²
JIB	21.49 ft	18.73 ft	7.64 ft	6 oz	71 ft ²
SPINNAKER	22.97 ft	22.97 ft	15.75 ft	3/4 oz	345 ft ²

Mainsail roach 2.49 located 60% up leach

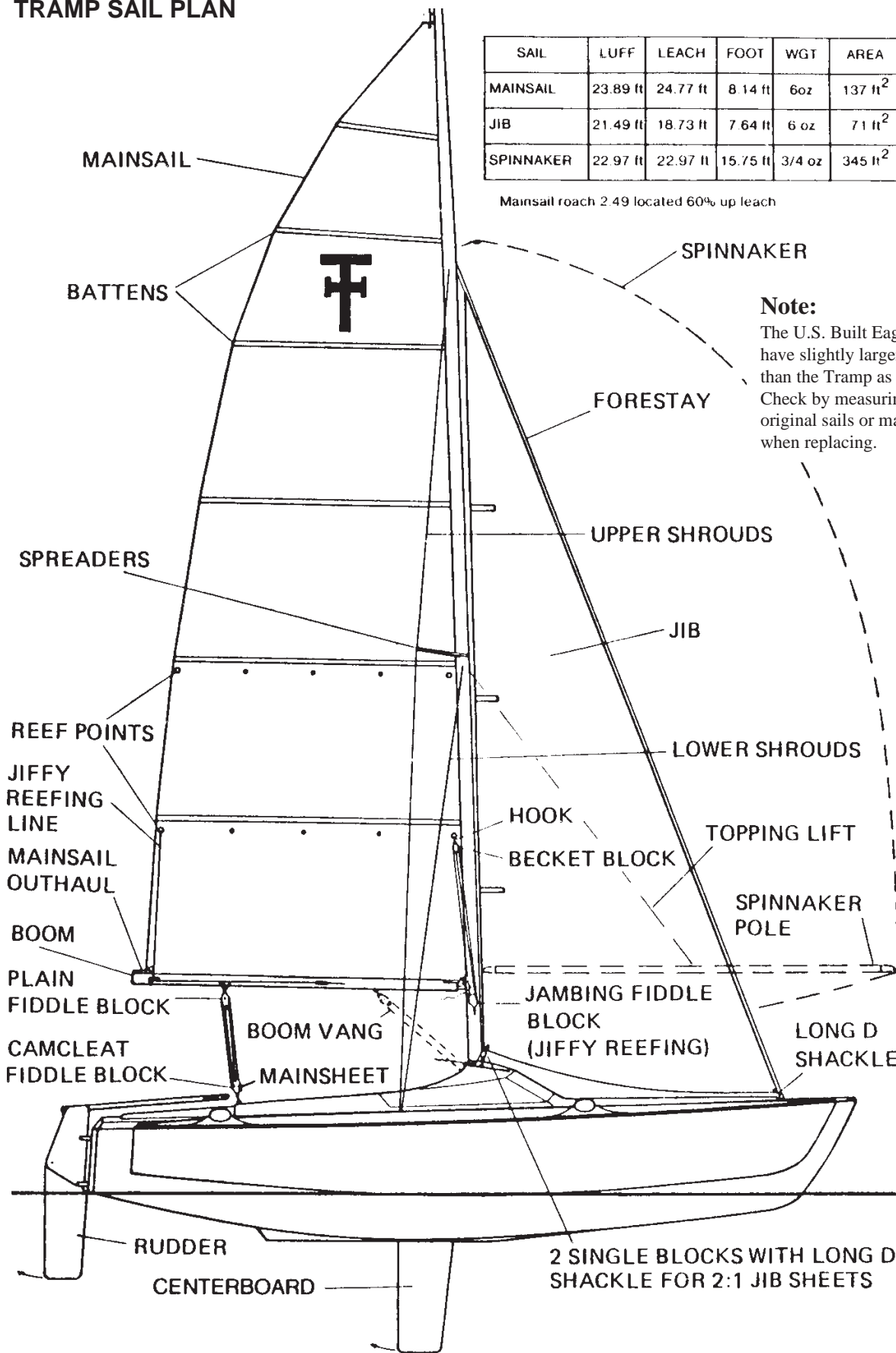

Note:

The U.S. Built Eagle may have slightly larger sails than the Tramp as shown. Check by measuring original sails or mast/rig when replacing.

2 SINGLE BLOCKS WITH LONG D SHACKLE FOR 2:1 JIB SHEETS

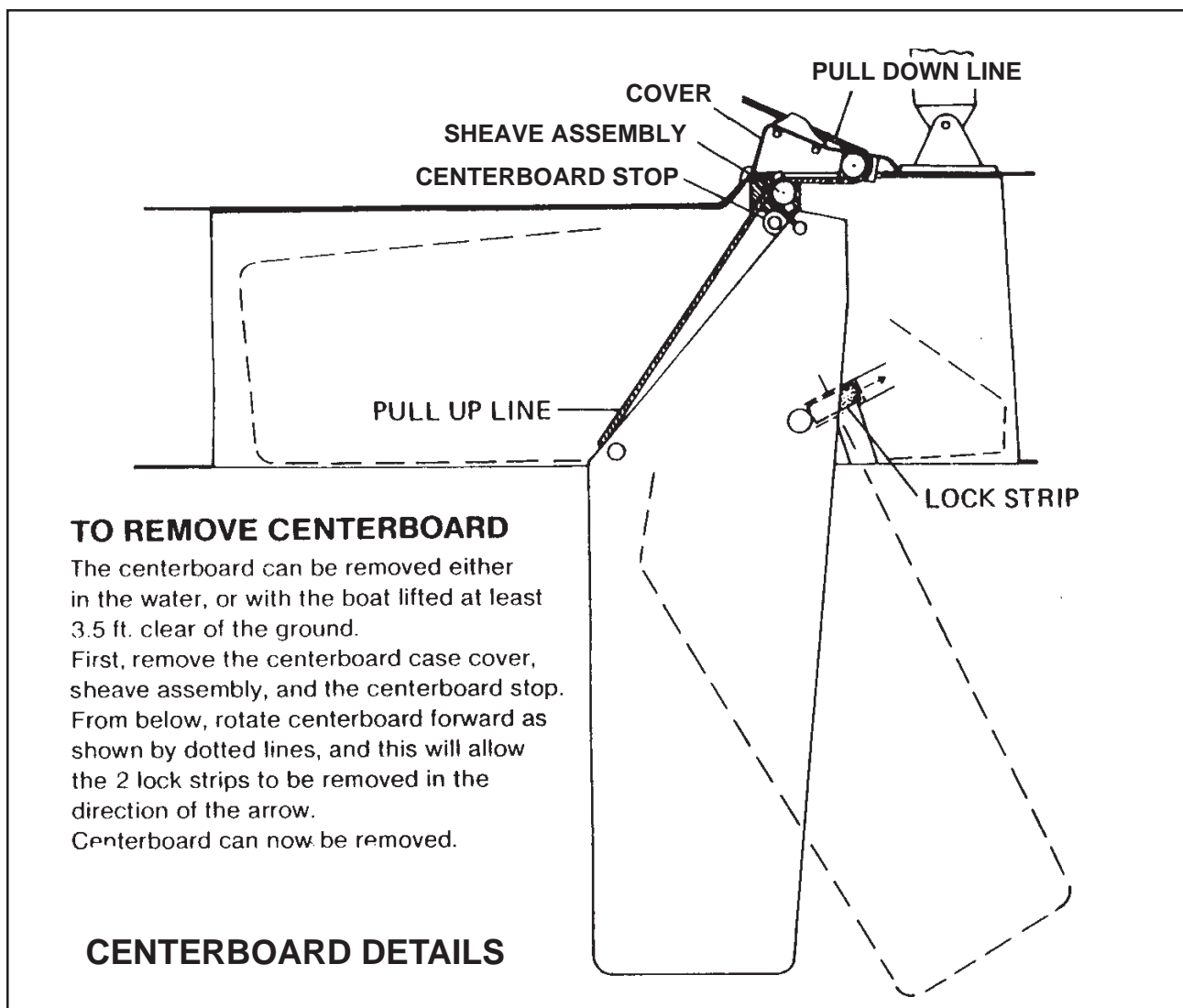

engine gives instant response and provides for a much smaller turning circle.

In general, however, both the rudder and centerboard should be completely extended while sailing with mainsail and jib for an efficient ride.

SAILING

The Tramp is sailed like any other yacht with the most notable difference being the lack of heel, and the quick response to the tiller. There is never any danger of losing control. You will find that the Tramp can point very high, but for superior speed it is better to come off the wind just slightly. Tacking is quick and effortless with little speed loss. Backwinding the jib is never required.

Reaching (across the wind) is the fastest point of sailing, with the sails being let out to about 45 degrees from the boat centerline. To improve the

jib setting, a barber hauler can be set up. This is a line hooked to the jib clew, running to the forward eye of the float deck wing net rail, and then back to the middle cam cleat and deadeye on the cockpit coaming. This gives a wide range of sheet adjustment possibilities.

When sailing in heavy weather, the primary rule is to always reef early, for safe and enjoyable sailing. Any trailer yacht can capsize, and the Tramp is no exception. But fortunately, capsizes are easy to avoid, provided that a few simple rules are followed:

1. Always listen to weather forecasts before sailing and keep alert throughout the day for possible weather changes.
2. If bad weather is approaching, reef early. Sailing should be enjoyable and early reefing makes it much more so.
3. When the winds are very strong and gusty,

always hold the mainsheet in hand, ready for instant release.

4. Monohull trailer yachts capsize most frequently after broaching, while running downwind. The Tramp, with much more superior directional control, is unlikely to have any problem in this regard. The only real danger would be being caught broadside to a severe gust with the sails sheeted in tightly. Be especially wary after tacking in heavy weather, not to bear off too much on the new tack with the mainsail still sheeted in tightly.

5. If in very bad storm conditions, then the jib only should be used, which makes handling very easy and safe, or as a last resort, take all sails down and lay beam to the wind. Or even anchor if necessary. With no sails, the Tramp will naturally rest beam to the wind. Because of its enormous beam, waves big enough to capsize her would be extremely remote in normal trailer yacht waters.

Probably the Tramp's most important safety feature, apart from the unsinkability, would be the submersible floats. These are critical developments in trimaran design and have been proven very successful in avoiding wind capsizes.

The main advantage is that the floats give a definite visual indication of how the Tramp is being pressed. If the lee float is consistently on the verge of submersion, then reefing should be done, or the sheets eased. The beauty of the system is that even if the float submerges fully, there is still a large safety margin, as the wind will spill from the sails with the increasing heel angle. Because of this, the Tramp will still right herself even from a 50 to 60 degree heel angle. The theoretical wind speed to submerge the lee float to the rubber molding, with full sail, is approximately 32 knots, giving a very large safety margin.

Sailing can be done with the bimini cabin up as the boom is well over the top, all sail controls are still readily accessible, and visibility is unaffected. If

needed, the vinyl cabin can be placed over the bimini and fitted to the sides for complete protection, yet still retaining the ability to sail.

REEFING

The Tramp has jiffy reefing, with two reefs fitted as standard. Although not used every time out on the water, it is a good idea to become familiar with its operation and to have an occasional practice run. To set up, the 3 : 1 reefing tackle is shackled to the eye of the mast just below the gooseneck, and the stainless steel hook fastened to the first reef tack cringle on the mainsail luff.

At the aft end of the boom, the reefing line is tied to the anchor pin on the stainless steel cheek block, passed under the boom, up the sail and through the first reef cringle on the leach, back down to the cheek block, and then forward to the cleat on the boom.



To reef, first ease the mainsail halyard to a predetermined position, and then pull on the reef tack downhaul, then the reef clew outhaul. The cringles on the foot of

the sail can now be used to secure the sail along with the boom.

Generally, the first reef can go in around 20 knots.

SPINNAKER

The optional spinnaker is a very easy sail to use on the Tramp. Because of the extremely wide beam and level sailing, there are no control problems. The spinnaker becomes a very practical and safe sail for family sailing and can be used either with, or without a pole.

To use without the pole, single blocks are shackled to the eyes on the float bows and also to the outer ends of the aft beams. A brace line, with a single block at the bow end, is passed from the spinnaker through the float bow block and back through the forward cam cleat on the cockpit coaming, on each side. The spinnaker sheet is now passed through the block on the aft beams,

and then through the aft cam cleat on the cockpit coaming. This is also done on each side.

The spinnaker can be hoisted from either the forward hatch, or the cockpit. For running downwind, both the brace and sheet are used for setting. On a reach, the windward brace is let off, so that the aft beam becomes the sheeting point. To jibe, simply let off the windward brace and pull on the leeward one, adjusting the sheets as required.

To use the pole, only the sheets to the aft beam are required. But for better adjustments, the braces can be fitted to the forward beams.

ANCHORING

Trimarans tend to be lively at anchor, gently sailing from one side to another. To prevent this, a bridle can be used from the float bows, or alternatively anchor from the stern, except when very rough.

SAFETY POINTS

Always carry full safety gear to include life jackets, etc., as required by U.S. Coast Guard and local regulations.

The Tramp has a total of seven major watertight sections plus foam buoyancy which makes it virtually unsinkable. An important point to remember, however, is that if a float is damaged below the waterline causing a hole to exist, do not open the inspection hatch. The float should be airtight and removal of the hatch would allow the entire float to flood. With the hatch in place, an airlock is formed and water cannot enter. Even with the float keel completely ripped out the airlock would be maintained and the float remain buoyant. Heeling the Tramp the other way would allow the water to drain out.

RETRIEVING

For convenience, the floats should be folded before arriving at the ramp, since a folded, narrow beam is easier to manage and it allows the floats to be useful step off points, if needed. To fold, loosen, and release all bolts with the speed wrench. Grasp the handle on the rear beam and lift upward, taking care not to let the float swing too fast against the center hull. Insert the beam/hull lockpins and the Tramp is now ready for the

trailer. If the float does not fold fully, the usual cause is the wingnets catching on the aft cockpit coaming. To fix this, push the wingnet lashing down so that it will slide under the coaming.

As with launching, there is no need to completely submerge the trailer to retrieve the boat. Connect the winch wire to the bow eye, straighten the boat, and commence winching. The tilt can be used, if wished. Check that the keel comes up on the center of the rollers, and make sure that the float bows do not hook under the float supports. If the float bows touch the wheel guards, it usually means there is too much incline on the ramp.

DE-RIGGING

De-rigging is basically the reverse procedure of rigging. Remove the jib, mainsail, and boom. Disconnect the forestay. Insert the forward and aft mast supports. Stand in the cockpit behind the mast and remove the mast retaining pin. Walk the mast back to the aft end of the cockpit, gently allowing it to fall back onto the mast support at the transom.

Lift the mast off the step and up through the cabin roof slot. Walk it forward until the spreaders are between the cabin roof and the forward beams. Rest the forward mast end on the support crutch at the front end of the anchor well. Tie it securely and also tie the halyards to the mast at two or three points along its length to prevent mast chafing while in tow. The rudder can be left on or off. If left on it should be tied to one side and the blade lifted up. Ensure that the float supports are against the floats and that the floats are tied down to the trailer.

MAINTENANCE

After every sail, always wash the boat and trailer down' with fresh water, and check floats and main hull bilge for any water. Sails should be rolled or folded, and dried if wet. Do not leave them in sunlight. Seat cushions should be stored under cover.

All folding system bolts and nuts should be occasionally checked for tightness, as should the float to beam holding nuts. The stainless steel beam bolts should periodically have their threads lightly oiled.

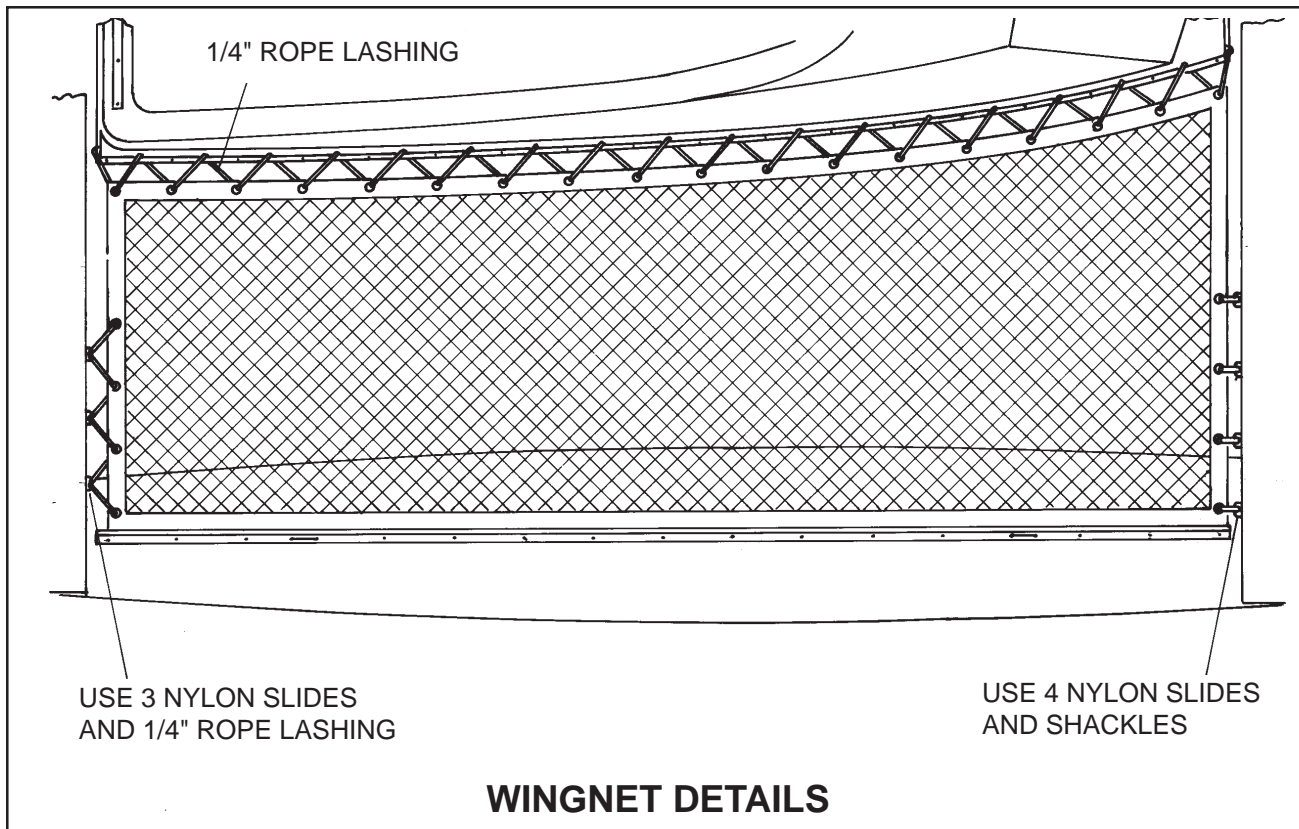

The Tramp comes complete with the following standard items:

- 1 Mast and boom, complete with rigging wires, internal halyards, and tralinging mast supports
- 1 Rudder
- 1 Pulpit (bow rail)
- 1 Mainsail including battens
- 1 Jib
- 1 Mainsheet
- 1 Mainsheet plain fiddle block
- 1 Mainsheet camcleat fiddle block
- 1 Mainsheet outhaul line with shackle
- 1 Mainsheet traveller control line
- 2 Long d shackles (jib tack and clew)
- 2 Small swivel blocks (Jib clew)
- 2 Jib sheets
- 1 Small jamming fiddle block (jiffy reefing) and shackle
- 1 Small becket block (jiffy reefing) and shackle
- 1 Stainless steel hook (jiffy reefing)
- 3 Jiffy reefing lines
- 2 Float tie down ropes
- 1 Mast/cabin retaining pin with 2 spring clips
- 1 Beam bolt speed wrench
- 2 Rubber bungs (cockpit drains)
- 1 Sailing Manual

OPTIONAL EXTRAS

- Spinnaker -
- 2 spinnaker sheets
- 2 spinnaker braces

- 4 single blocks
- 1 downhaul with hook
- Spinnaker pole
- Boom Vang
- Seat cushions
- Floor Cushions
- Vinyl cockpit side pockets
- Bimini top
- Vinyl cabin (includes bimini and complete snap on cover)

FITTING WINGNETS

The wingnet should be attached with a float extended (one at a time) on land. If attached when the float is folded, the wingnet tends to be too tight as the float unfolds. Therefore, the following steps should be taken:

1. Unlock the beams from the main hull
2. Lower the trailer float support as far down as possible
3. With two people, slowly extend the float
4. With one person holding the float in the extended position, the other person should bolt the beams down using the speed wrench
5. Two supports should then be placed underneath the extended float to maintain a level boat attitude

6. Slide the wingnet into the float rail wing net slot starting aft and working forward. Pliers will help pull the net along.
7. Insert the slides into the beam slots and attach the fore and aft ends of the wingnet to the beam (refer to illustration)
8. Starting aft and working forward, tightly lash the inboard edge of the wingnet to the main hull
9. Unlock the main beam bolts and fold the float, locking the beams to the main hull with the two locking pins
10. Repeat steps 1 - 9 for the other float

Once the wingnets are attached, they are permanently attached for the life of the net. Only occasional tightening is necessary.

ADDITIONAL DETAILS FOR THE SUPER TRAMP

RIGGING

The same procedure is used as with the standard Tramp, except that the longer and heavier mast will require two people to raise it. The aft runner wires should be attached to the mast and their lower ends tied to the bottom of the mast.

The 8:1 runner tackles can be left connected to the outer ends of the aft beams with the wire blocks and snapshackles clipped to the genoa tracks while trailering. They can then be clipped to the runner wires once the mast is erected.

The aft runners must always be used in winds over 15 knots while going to windward. They maintain forestay tension and, more importantly, reduce the compression loading on the mast. The leeward runner can be slackened off while running to allow the mainsail to go fully out.

SAILING

The only major difference from the standard Tramp is the use of the optional genoa. This is intended only as a reaching sail in winds over 10 knots, or for going to windward where no tacking is required. It can be tacked, if wished, by either walking it around the forestay or using a drawline from the luff.

To set it up, a double ended tack line is threaded

through the small single block fitted to the bow eye, with the tack line passing either side of the forestay. A tack snapshackle should be fitted to the tack of the genoa.

To hoist, the genoa tack is shackled to the appropriate end of the tack line (eg. the starboard line when on the port tack) and the spinnaker halyard is connected to the genoa head. Pull the genoa tack to the bow by the tack line, and then hoist with the spinnaker halyard. To tighten the luff, the tack line is taken to the cabin roof winch and then cleated. It is sheeted to the genoa tack on the aft coaming, using a 2:1 sheet with a ratchet block and camcleat and snapshackle.

REEFING

The Super Tramp has an internal jiffy reefing system, for fast and very easy reefing. When not in use, the reefing lines lay along each side of the boom, hooked into the appropriate eyes. The luff uses the same system as the standard Tramp, with a 3:1 tackle fitted on the mast.

To reef, unhook either boom reefing line and hook into the first reefing cringle, on the leach. Ease the halyard and pull on the reef tack downhaul, then the leach reefing line. The reefed part of the sail is then bundled up and tied along the sail foot. Do not tie around the boom. This is unnecessary with a loose footed sail.

For the next reef, the luff tackle is hooked into the next tack cringle, while for the leach, the unused reefing line on the other side of the boom is hooked into the next leach cringle. The next reef can then be pulled down.

SPINNAKER

The same procedures apply as with the standard Tramp, except that ratchet blocks are used for the sheets, as are the cabin roof winches. These allow easy adjustment under high loads.

SUPER TRAMP - SAIL PLAN

SAIL	LUFF	LEACH	FOOT	WGT	AREA
MAINSAIL	27.49 ft	28.25 ft	8.14 ft	6oz	149 ft ²
JIB	24.28 ft	21.56 ft	7.68 ft	6 oz	84 ft ²
SPINNAKER	25.92 ft	25.92 ft	16.41 ft	3/4 oz	420 ft ²
GENOA	24.94 ft	21.88 ft	13.32 ft	5.3 oz	150 ft ²

Mainsail roach 1.9 ft. located 15.7 ft. up leach
 Genoa fitted with 1/8 inch wire luff

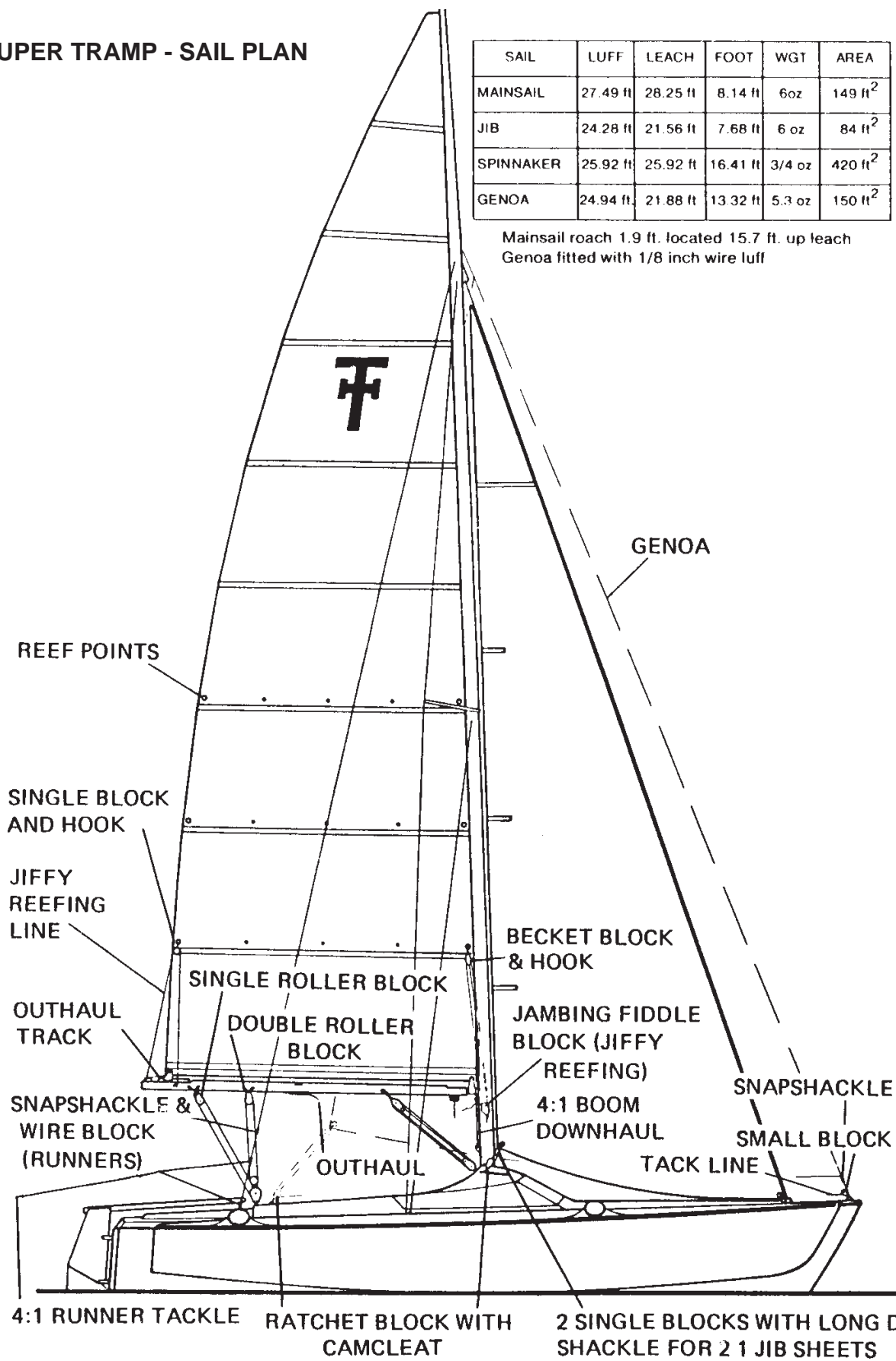

4:1 RUNNER TACKLE

RATCHET BLOCK WITH CAMCLEAT

2 SINGLE BLOCKS WITH LONG D SHACKLE FOR 2 1 JIB SHEETS