

Sail	Luff	Leach	Foot	Wgt.	Area
Mainsail	11275 37'	11880 39'	4302 14' 1"	320gm 7.5oz	36sq. m. 389sq.ft.
Jib	10997 36' 1"	9775 32' 1"	3895 12' 9"	320gm 7.5oz	19.4sq.m. 210sq.ft.
Genoa	10997 36' 1"	9752 32'	5153 16' 11"	270gm 6.5oz	25.7sq.m. 278sq.ft.
Asymmetric Spinnaker	12700 41' 8"	10800 35' 5"	8600 28' 3"	35gm N 0.8oz N	93sq.m. 1004sq.ft.
	Vert. Hoist 10800/35' 6"	JC 5000/16' 5"		70gm/1.5oz (opt. for Cruising boats)	
Storm Jib	7000 22' 11"	5624 18' 5"	3152 10' 4"	350gm 8.5oz	8.7sq.m. 94sq.ft.

MAINSAIL CAMBER:
 Top Third 10% at 44% aft
 Middle 12% at 48% aft
 Bottom Third 6% at 46% aft
 Mast pre-bend is 75mm (3")
 Camber position must be as shown. Do not move forward as with a rotating mast catamaran.
This does not work on a fixed mast trimaran.

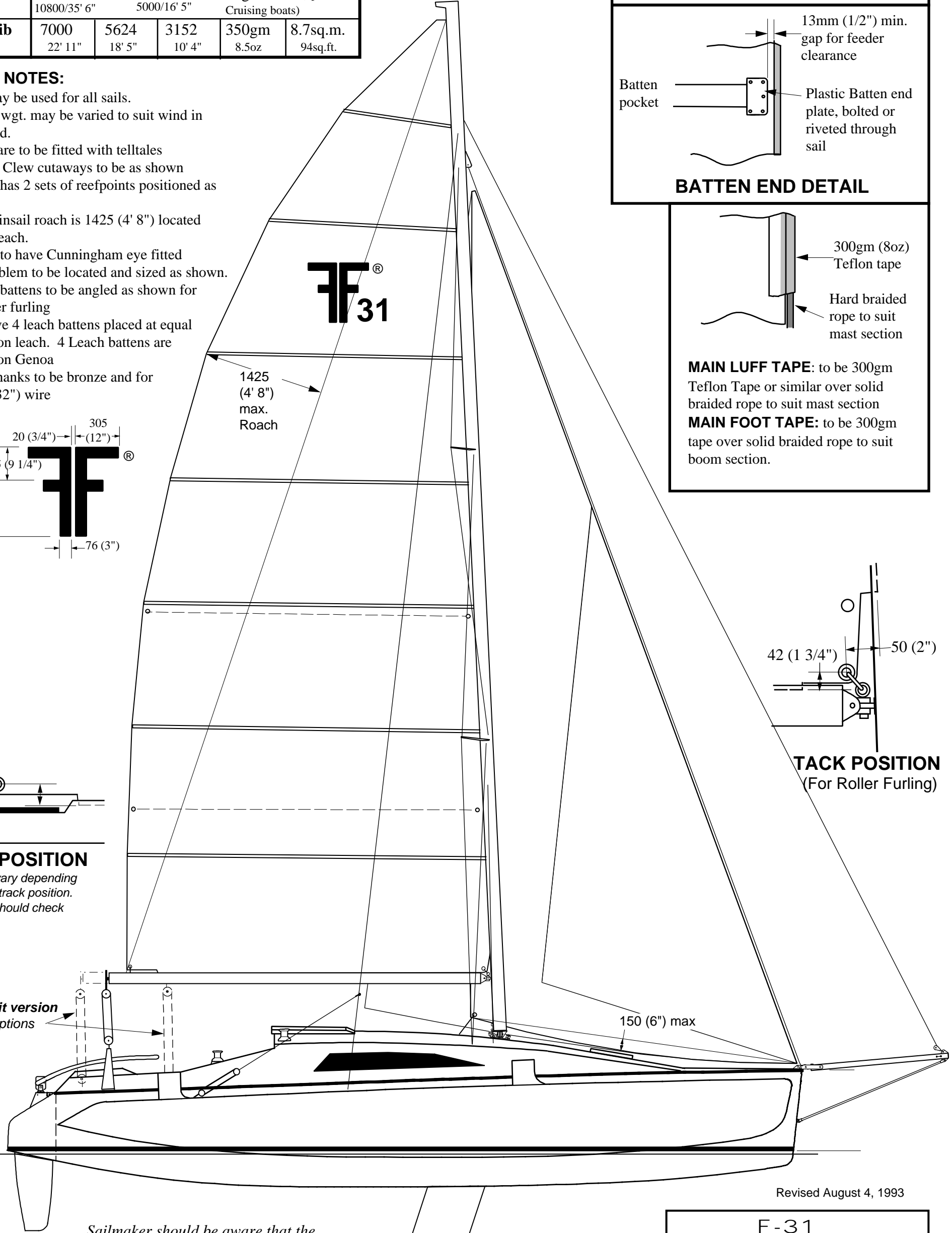
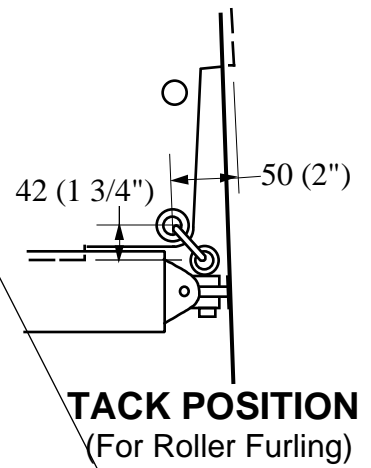
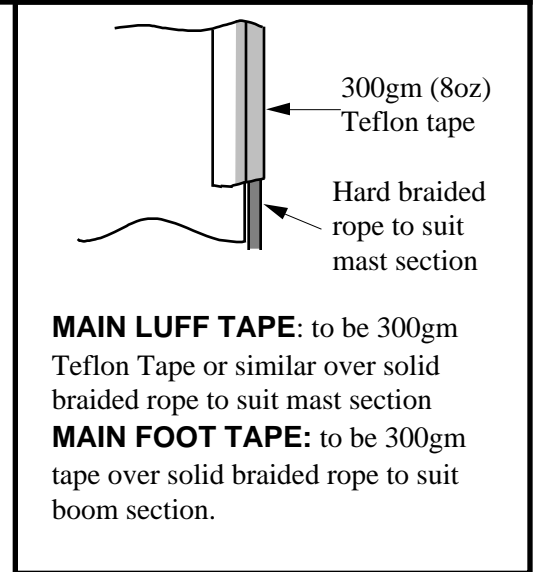
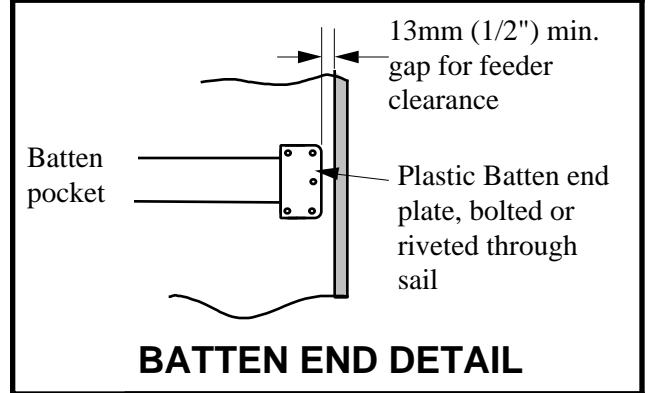
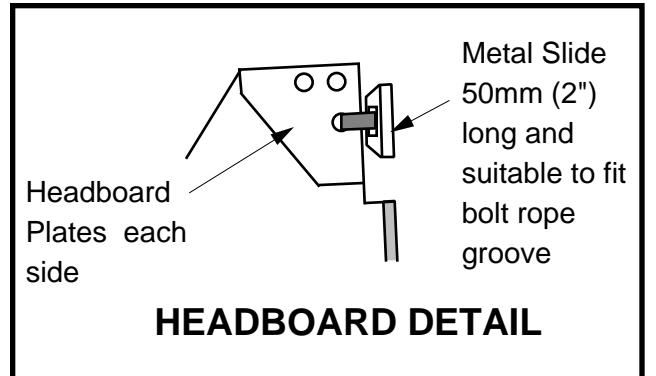

NOTES:

- Mylar may be used for all sails.
- Sailcloth wgt. may be varied to suit wind in area sailed.
- All sails are to be fitted with telltales
- Tack and Clew cutaways to be as shown
- Mainsail has 2 sets of reefpoints positioned as shown
- Max. Mainsail roach is 1425 (4' 8") located 60% up leach.
- Mainsail to have Cunningham eye fitted
- Class emblem to be located and sized as shown.
- Mainsail battens to be angled as shown for easy roller furling
- Jib to have 4 leach battens placed at equal distance on leach. 4 Leach battens are optional on Genoa
- Foresail hanks to be bronze and for 7mm (9/32") wire

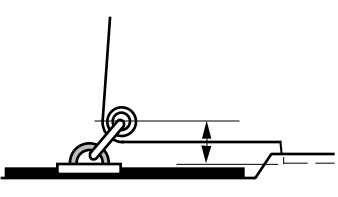
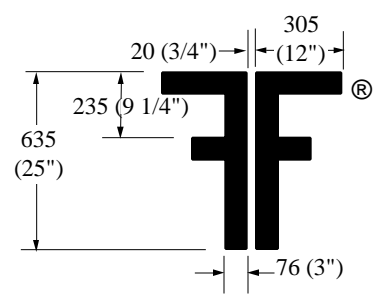

CLEW POSITION

Height will vary depending on Outhaul track position. Sailmaker should check with owner

Aft Cockpit version
Sheeting options

Sailmaker should be aware that the loadings on a Multihull's sails are considerably higher than an equivalent monohull due to the much greater maximum stability (47,000ft. lbs)

Revised August 4, 1993

F-31
STOCK SAIL PLAN
A Design By Ian Farrier P.O. Box 40675, Bellevue, WA 98015-4675