

**NOTES:**

Square Top Mainsail as shown is required to be Class legal.

Mainsail is designed to be almost flush with the top of the mast as shown -do not shorten luff, which has cutout as shown for halyard clearance.

Vertical Batten to be used at head to ensure head stands vertical.

All eyelets and reinforcing must be extra heavy to suit the very high loads possible with a multihull.

**Changes**

- 4/9/98
- Mainsail luff reduced from 40.7' to 40.55'
- Mainsail leached reduced from 42.4' to 42.25'
- Cutout for halyard clearance increased from 6"/150to 7"/180
- Reefing points defined
- 12/28/98
- Eyelets added for reefing ties
- Note added on bolt rope and slides
- Note added on strength of eyelets.
- 3/4/99 Model designation noted

This sail plan covers the following models:

- F-31:** stock boat from 1999 on with rotating aluminum wing mast
- F-31R:** stripped racing boat with rotating carbon mast
- F-31RS:** stripped racing boat with rotating aluminum wing mast

4/10/98: Reef points best located where shown to locate headboard at reinforced track area of carbon mast when reefed

142"  
3605

66"  
1676

Sheet here with aft cabin version

Optional boomless main (will require higher mainsheet purchase)

Mast is 1 3/4" (45mm) aft from orig. stock non rotating mast position

Sail	Luff	Leach	Foot	Area	Remarks	Material
<b>Mainsail</b>	40.55' 12360	42.25' 12875	14.3' 4360	429sq.ft 39.7sq.m.	38" head 34" roach	Technora
<b>Jib</b>	34.3' 10450	30.3' 9235	13.5' 4115	218sq.ft 20.2sq.m.	10" roach LP 11.75'	Technora
<b>Asymmetric Spinnaker</b>	45.2 13780	39.7' 12100	29.75' 9070	996sq.ft 92.2sq.m.	.83SMG	Nylon
<b>Screacher</b>	39' 11890	34.8' 10610	25.8' 7865	449sq.ft 41.6sq.m.	5mm (7/32") wire or 9mm (3/8") Kv. Luff	Mylar
<b>Opt. Boomless Mainsail</b>	41.9' 12770	43.5' 13260	14.3' 4360	449sq.ft 41.6sq.m.		Technora

Mast length is 42' 6" (12.95m)

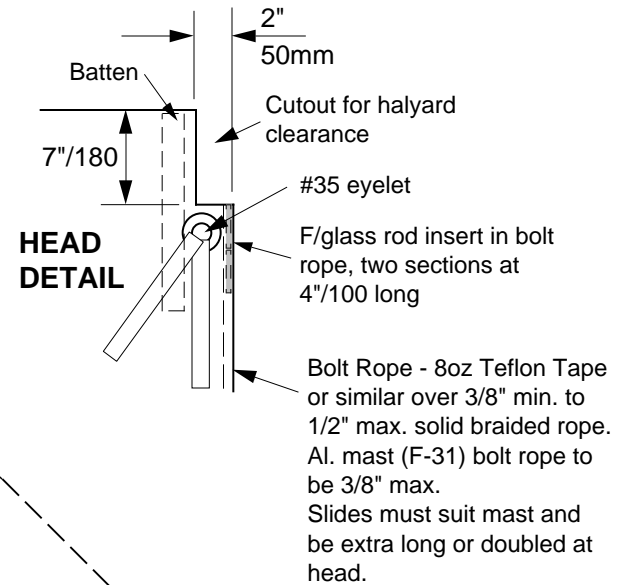

**THIS DRAWING EXPIRES July 1st 2000**

Request a new copy after this date or the latest version is always available from <http://www.farriermarine.com/sails.html>

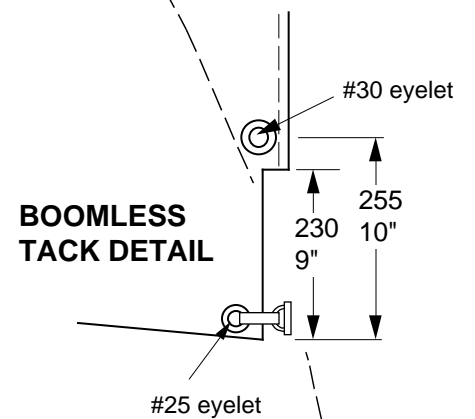

Revised September 2, 1999

**F-31 & F-31R™ SAIL PLAN**

Farrier Marine, Inc.  
P.O. Box 40675, Bellevue, WA 98015-4675